

## DLV-R 3.5 Inch Tilt Downlight



### Product Overview

**Dimensions:**

Trim ring diameter: 103mm  
 Height: 76mm  
 Cut-out: 92mm  
 Total weight : 0.24Kg (Excluding LED Driver)

**Ingress Protection:**

IP rating: 20

**High quality LED:**

CRI ≥ 80 as a standard  
 3000K, 3500K and 4000K as a standard  
 Colour consistency with a low Mac Adams step of SDCM ≤ 3  
 Alternative CCT and CRI available on request

**Remote LED driver:**

Plug and play with male and female connectors  
 220 – 240V input (50/60 Hz)  
 Ripple and flicker free (≤ 3 %)  
 Power factor ≥ 0.90  
 Surge protection: 3.75 KVA  
 DALI or trailing edge available on request

**Aluminium Reflector:**

60° as a standard  
 36° and 45° available on request

**Heatsink Material:**

Die cast aluminium heatsink for increased heat dissipating properties to increase life of LED component  
 L&B rating up to L90B10 ≥ 100 000hrs

**Trim Ring:**

Die cast aluminium  
 White and black as a standard  
 Other colours available on request

**Emergency Kit:**

1hr as a standard (Ta ≤ 25°C)  
 3hr available on request

Standard Warranty of luminaire is 5 years subjected to T's and C's

**Application:**

Providing a selection of lumen outputs and reflector choices tailored for diverse recessed lighting needs (suitable for operating temperatures up to 35°C), spanning from ambient to accent lighting applications.

Applications include entrances, corridors, hallways, reception areas, retail spaces, hospitality venues, high-end residential properties, and beyond.



Commercial



Public Facilities



Hospitality



Retail



Residential

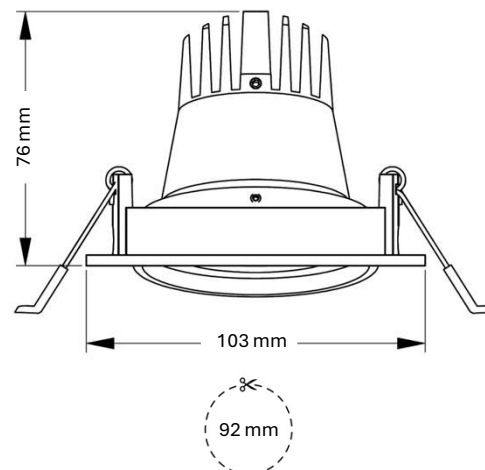

## DLV-R 3.5 Inch Tilt Downlight

CCT (K)	Drive current (mA)	Voltage (V)	Nominal Wattage (W)	Nominal Lumens (lm)	System Wattage (W)	System Lumens (lm)
3000	350	25.0	9.0	1 425	9.6	1 155
3000	500	25.9	13.0	1 965	14.3	1 592
3500	350	25.0	9.0	1 456	9.6	1 180
3500	500	25.9	13.0	2 005	14.3	1 624
4000	350	25.0	9.0	1 471	9.6	1 192
4000	500	25.9	13.0	2 026	14.3	1 641

## Code Sequence

Model	Colour	Beam	LED	CRI	CCT	Nominal Power	Additional
DLV-R 3.5 Inch Tilt - 1201	White - 1 Black - 2 Other - 0	36° - 36 45° - 45 60° - 60	BR - BR	≥ 80 - 8 ≥ 90 - 9 Other - 0	3000K - 30 3500K - 35 4000K - 40 5000K - 50 Other - 00	9W - /09/350 13W - /13/500	DALI - /DA Trailing Dim - /DT

### Model Example:

DLV-R 3.5 Inch White 36° BR ≥80 3500K 9W

### Code Sequence

1011 1 36 BR 8 35 /09/35

Use code Sequence for placements of orders

For **Other** options, please consult **Design Ignito B.V.**

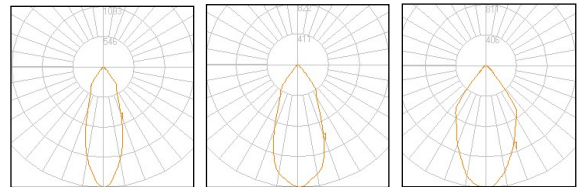

36°

45°

60°

Standard

## DLV-R 3.5 Inch Tilt Downlight packaging

Packaging	Dimensions (cm)	Net weight (Kg)	Gross Weight (Kg)	Units
Box Size	12.5 x 12.5 x 10.5	0.24	0.300	1
Carton Size	52.0 x 39 x 34.0		11.36	18

Confirm with **Design Ignito B.V.** accurate weights and dimensions based on component availability and dimension changes

5-year warranty

Tolerance range of optical and electrical data is ± 10%.

Optical and electrical data may increase or decrease with a change of specifications and availability of components.

Please note: Data may be rounded up/down for illustrative purposes. We reserve the right to amend or change details without prior notification. E&OE V2026.01.01.